

Thermal and Mechanical Properties of Electro-Slag Cast Steel for Hot Working Tools

Young Hoon Moon*

Department of Mechanical Engineering/Engineering Research Center for Net Shape and Die Manufacturing Technology, Pusan National University, Jangjeon Dong, Geumjeong Gu, Pusan 609-735, Korea

Boo Hyun Kang

Department of Mechanical Engineering, Pusan National University, Jangjeon Dong, Geumjeong Gu, Pusan 609-735, Korea

Chester J. Van Tyne

Department of Metallurgical and Materials Engineering, Colorado School of Mines, Golden, CO 80401, USA

The thermal and mechanical properties of an electro-slag cast steel of a similar chemical composition with an AISI-6F2 steel are investigated and compared with a forged AISI-6F2 steel. AISI-6F2 is a hot-working tool steel. Electro-slag casting (ESC) is a method of producing ingots in a water-cooled metal mold by the heat generated in an electrically conductive slag when current passes through a consumable electrode. The ESC method provides the possibility of producing material for the high quality hot-working tools and ingots directly into a desirable shape. In the present study, the thermal and mechanical properties of yield strength, tensile strength, hardness, impact toughness, wear resistance, thermal fatigue resistance, and thermal shock resistance for electro-slag cast and forged steel are experimentally measured for both annealed and quenched and tempered heat treatment conditions. It has been found that the electro-slag cast steel has comparable thermal and mechanical properties to the forged steel.

Key Words : Electro-Slag Cast Steel, Tensile Test, Hardness Test, Impact Test, Wear Test, Thermal Fatigue Test, Thermal Shock Test

1. Introduction

Electro-slag casting (ESC) (Medovar, 1989, 1991, Paton, 1980) is a method of producing ingots of various shapes in a water cooled metal mold by the heat generated in a conductive slag,

when electric current passes through a consumable electrode. In general, cast metal has inferior mechanical properties as compared to forged metal. Compared to forged metal, cast metal is less homogeneous in chemistry and physical properties, as well as having less stable mechanical properties. In all of the traditional casting methods, the molten metal is prepared in a melting furnace or ladle prior to being poured into the mold. The properties of cast metal are usually inferior to those of mechanically processed materials, due to the secondary oxidation of the metal stream as it is being poured. Additionally, reactions with the atmospheric gases and ambient air inside the mold and erosion of the mold can

* Corresponding Author,
E-mail: yhmoon@pusan.ac.kr
TEL +82-51-510-2472, FAX +82-51-512-1722
Department of Mechanical Engineering/Engineering Research Center for Net Shape and Die Manufacturing Technology, Pusan National University, Jangjeon Dong, Geumjeong Gu, Pusan 609-735, Korea (Manuscript Received March 15, 2004, Revised December 13, 2004)

contaminate the metal with inclusions. The entire amount of metal for the ingot is poured into the casting mold at one time. During the solidification of the ingot, flaws can initiate within the metal due to segregation and shrinkage, which can occur both on solidification and cooling. This casting segregation can produce large variations in chemistry and physical properties throughout the ingot.

For the ESC process, the detrimental effects of the traditional casting process can be largely eliminated. ESC is a method of producing ingots in a water-cooled metal mold, shown in Fig. 1. It is based on the electro-slag process of melting a consumable electrode. Moreover, the ESC method provides the possibility of producing high-quality metal components and ingots directly into a desired shape. Unlike traditional casting methods, ESC melts the metal in a processing unit contiguous with the mold itself. The heat generated in the conductive slag when electric current passes through it melts a consumable electrode. In the ESC method, like in other electro-slag processing operations, the source of heat energy is the molten slag. The ESC technology for billet production has significant advantages over conventional casting methods; these in-

clude no melting furnaces, no casting ladles, no molding mixtures, and no sand molds. The ingot is produced without the need to crop a shrinkage pipe, since the shaping and solidification conditions avoid conditions inherent to the conventional casting process that produces such shrinkage defects.

Because a hot-working tool is exposed to both severe thermal and mechanical stresses during use, the properties of the tool material must meet very stringent requirements (Baligidad, 1998 ; Dieter, 1987 ; Kwon, 2002). In this study, both thermal and mechanical properties of ESC steel have been experimentally measured and compared with properties obtained from a forged steel of similar composition and similar heat treatment. The hot-working tool steel grade, AISI-6F2, was chosen as the material for the study.

2. Experimental Details

2.1 Materials preparation

Figure 2 shows the shape of the consumable electrode used in the electro-slag casting process.

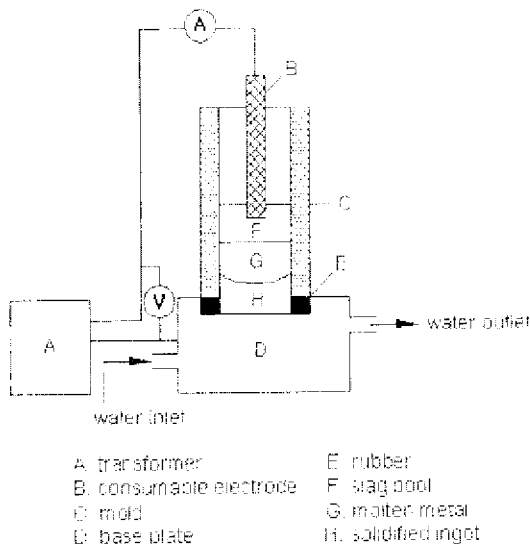

Fig. 1 Schematic drawing of electro-slag casting (ESC) process

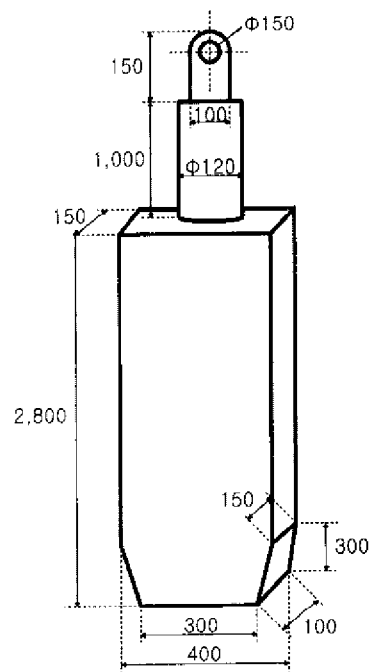

Fig. 2 Schematic drawing of consumable electrode (units of mm)

Table 1 Chemical composition

AISI-grade	C	Si	Mn	P	S	Ni	Cr	Mo	V	Al
6F2	0.50	0.21	1.02	0.014	0.003	1.5	0.96	0.48	0.12	0.004
6F2 (ESC)	0.49	0.23	0.96	0.013	0.005	1.9	0.95	0.48	0.11	0.007

Table 2 Electro-slag casting conditions

Test Variable	Input Value	Remarks
Flux	66%CaF ₂ -28%Al ₂ O ₃ -5%CaO	-
Slag Height (cm)	11	-
Current (kA)	10-12	-
Voltage (V)	38-45	Voltage in slag pool

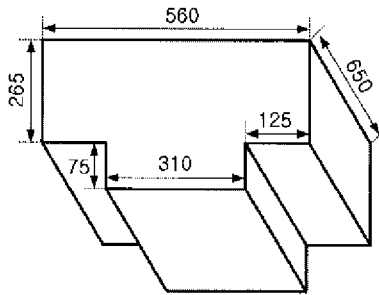
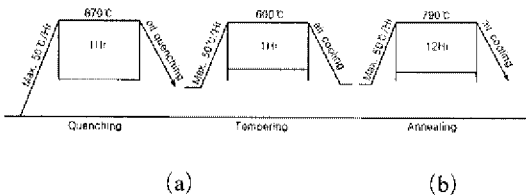
**Fig. 3** Schematic drawing of electro-slag cast ingot (units of mm)**Fig. 4** Heat treatment curves for (a) quenched and tempered and (b) annealed

The chemical composition of electro-slag cast steel is almost the same as that of AISI-6F2 because the consumable electrode for ESC process was made from AISI-6F2. Table 1 shows the chemical compositions of the two test materials. In this table, 6F2 (ESC) is the designation for the 'Electro-Slag Cast' steel.

Figure 3 shows the shape of the ingot produced by the electro-slag casting process. Table 2 gives the electro-slag casting processing conditions that were used.

Figure 4 shows the thermal cycles for both the annealed and the quenched and tempered heat treatments that were used in this study.

2.2 Thermal and mechanical testing procedures

2.2.1 Tensile and hardness tests

Tensile testing was performed on a servo-hydraulic mechanical testing machine at the temperatures of 300, 500, and 650°C. The size of specimen follows ASTM A370. The strain rate for tensile testing was 2×10^{-3} /s. High-temperature hardness testing was performed on a high temperature micro Vickers testing machine at 300, 500 and 700°C. The load for the micro Vickers tests was 500g. Reported hardness values are an average of five measurements for each material. To consider positional differences in electro-slag cast specimens, several positions on the upper and lower sides of ingots were tested.

2.2.2 Impact tests

In many manufacturing operations, tool materials are subjected to impact loading conditions, as in high speed metalworking operations such as drop forging. To estimate the impact toughness, Charpy impact tests were performed at room temperature. Figure 5 schematically shows the position of Charpy specimens, with respect to the casting direction. In case of forged 6F2 steel, test specimens were machined from longitudinally cut piece.

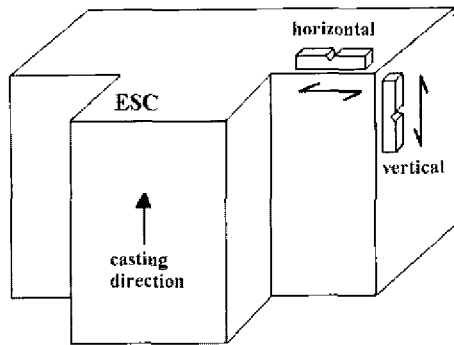

Fig. 5 Impact specimen direction in ESC ingot

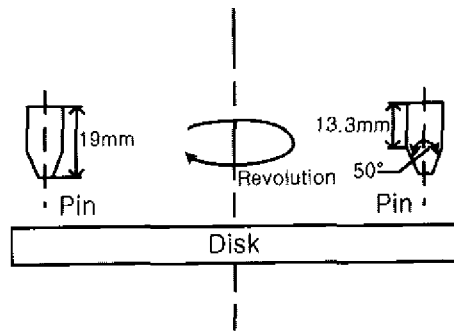

Fig. 6 Schematic drawing of pin-on-disk test apparatus

2.2.3 Wear tests

Tool wear has important technological and economic significance because it changes the shape of tools, causing changes to the die-workpiece interface and the shape of the forged component. To estimate the wear resistances of the tool steels, pin-on-disk wear tests, as shown in Fig. 6, were performed at two different rotation speeds (60 and 90 rpm) and 200 N of contact load. Test temperature were 25°C and the test time was 5 hours at each condition.

2.2.4 Thermal fatigue tests

Thermal stresses can lead to cracks in tools and dies (Starling, 1997; Kim, 1996). Figure 7 shows the thermal fatigue test machine used in this study.

Cylindrical specimens with a length of 18 mm and a diameter of 8 mm were tested. A fluctuating temperature cycle was imposed on the specimen with a minimum temperature, T_{min} , of 100°C

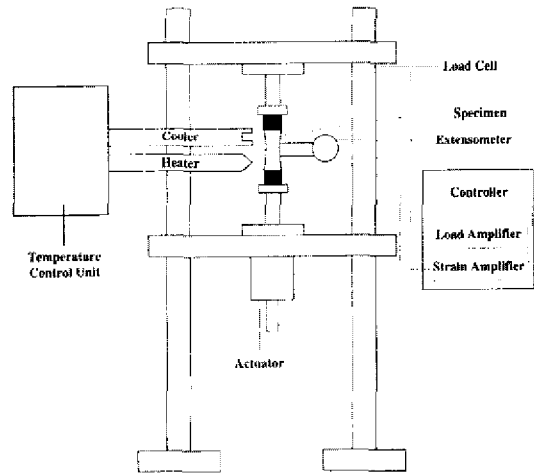

Fig. 7 Schematic drawing of the thermal fatigue testing machine

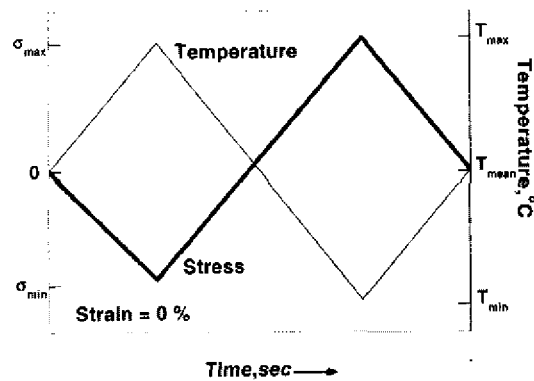

Fig. 8 The relationship between temperature and stress in thermal fatigue

and a maximum temperature, T_{max} , of 600°C. The heating and cooling rate between these temperatures was 10°C/s. Initially, the room temperature specimen was heated to the mean temperature. The mean temperature, T_{mean} , is the algebraic mean of the maximum and minimum temperature in the cycle. After the specimen is held at the mean temperature for 10 minutes to achieve thermal expansion and thermal equilibrium, the stroke control on the test machine was fixed so as not to produce any mechanical stresses. The temperature of the specimen was then cycled from T_{mean} to T_{max} to T_{mean} to T_{min} to T_{mean} . Hence, thermal stresses occur due to the dimensional changes in the specimen, as a result of the temperature change with an imposed con-

straint. This relationship is schematically shown in Fig. 8.

2.2.5 Thermal shock tests

Thermal shock is generally used to describe development of cracks after a single thermal cycle. Thermal stresses, which cause such cracking, are due to either temperature gradients in the material or by anisotropy of thermal expansion behavior. In this study, the relative thermal shock resistance of the material was measured by the modified Uddeholm test method (Norstrom, 1982; Collin, 2000; Moon, 2003). Figure 9 schematically shows the modified Uddeholm test method.

The specimen is inserted and preheated from room temperature to the predetermined temperature, and held for five minutes at this start

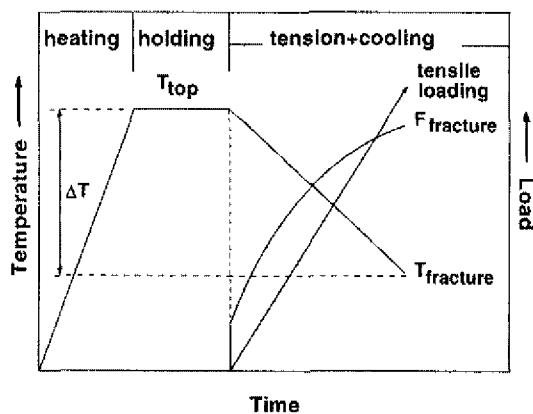

Fig. 9 Schematic drawing of modified thermal shock test method

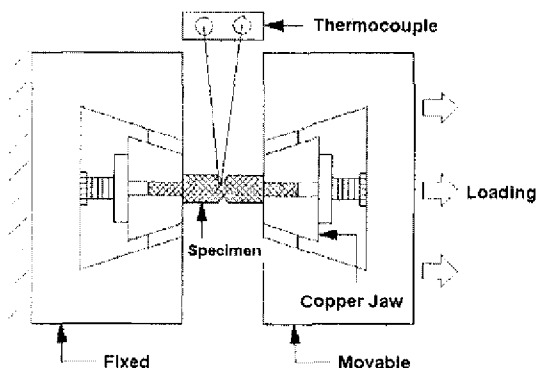

Fig. 10 Schematic drawing of loading mechanism in the Gleeble test machine

temperature. Then tensile loading, via a constant stroke rate, is applied with simultaneous cooling from the temperature, until specimen fracture occurs. The temperature at the instant of fracture is determined, and the difference (ΔT) between the start temperature and the fracture temperature is obtained. The parameter ΔT is defined as the relative index of the thermal shock resistance for the material. The larger the ΔT , the higher is the thermal shock resistance of the material. The thermal shock tests were performed on a Gleeble 3500 thermo-mechanical testing machine. Figure 10 shows a schematic of the loading mechanism. Cylindrical V-notched specimens having 10 mm diameter were used for the test. The notch has a depth of 2.5 mm, an angle of 60° , and a root radius of 0.1 mm.

The specimen is inserted and preheated from room temperature to the predetermined start temperature of 700°C , 800°C , or 900°C , at a rate of 10°C/s . The specimen was held for 300s at the start temperature, and then the tensile loading with constant stroke rate was applied with simultaneous cooling. The stroke rate was maintained at 10 mm/min and the cooling rate of the specimen was about 25°C/s .

3. Results and Discussion

3.1 Tensile properties

The service properties of conventionally made castings depend to a great extent on the quality of initial metal, structure of the casting metal and the design of casting. The electroslag casted metal has a directed, i.e. oriented structure due to a gradual melting of the casting, a shallow metal pool and extensive heat dissipation into the wall of cooled casting mould. An electroslag casted metal has a lower content of segregates and non-metallic inclusions. The boundaries of its crystals and boundaries of crystal meeting have much higher purity than those of open melting castings and this results in much better mechanical properties. Figure 11 shows the microstructure of electroslag casted 6F2 steel. In the annealed condition, the microstructures are composed by acicular ferrite and pearlite, while in the quenched



(a)

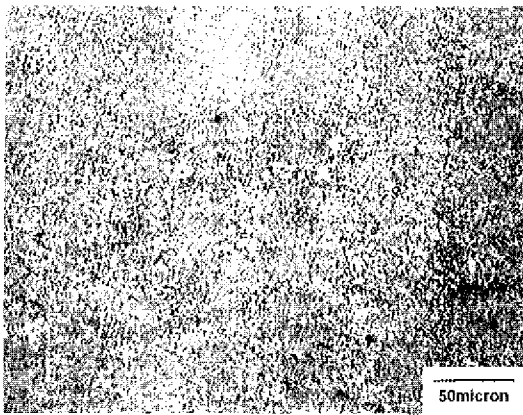

(b)

Fig. 11 Microstructures for (a) annealed and (b) quenched and tempered 6F2 (ESC)

and tempered condition, the microstructures are mainly changed into the tempered martensite.

The deformation behavior of materials at high temperatures can be estimated from the flow stress and the elongation at high temperature. Figure 12 shows the comparison of yield strength and tensile strength at elevated temperature. In the quenched and tempered condition, both forged 6F2 and 6F2 (ESC) steels show similar strengths, while in the annealed condition, the ESC steel shows significantly higher yield and tensile strengths as compared to the forged steel.

The total elongations measured at various temperatures are shown in Fig. 13. As expected from the yield and tensile strengths, the forged 6F2 and 6F2 (ESC) steels in the quenched and tempered condition show higher elongations, while in the

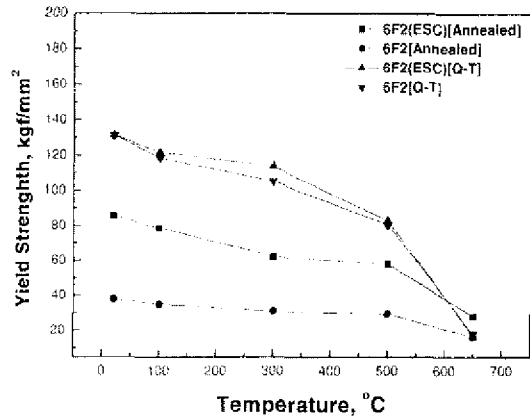

Fig. 12 Temperature dependency of yield strength

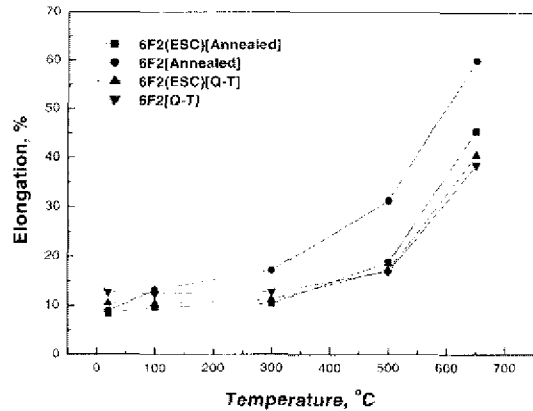

Fig. 13 Temperature dependency of elongation

annealed condition, forged 6F2 shows higher elongation than 6F2 (ESC).

The resistance of hot working tool steels to thermal attack is favored by the ability of the steel to accommodate both elastic and plastic deformation before fracture at elevated temperature. The superior resistance will be achieved by some optimal combination of strength and ductility in the material.

3.2 Hardness

Figure 14 shows hardness values measured at elevated temperatures. The hardness decreases with increasing temperature. For the quenched and tempered condition, both forged 6F2 and 6F2 (ESC) steels show similar hardnesses. For the annealed condition, 6F2 (ESC) has higher hardness than forged 6F2 steel.

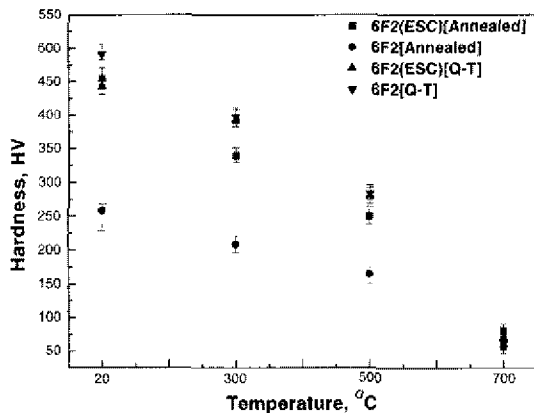

Fig. 14 Hardness values at elevated temperatures

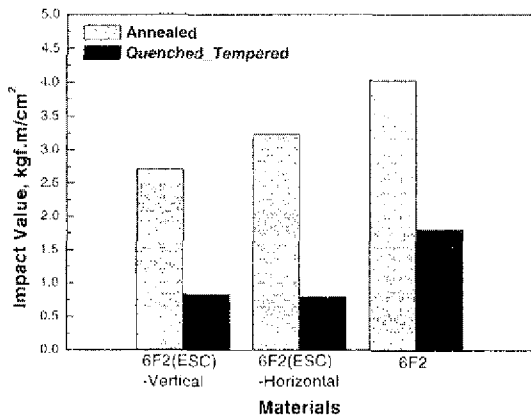

Fig. 15 Comparison of impact values at room temperature

3.3 Impact toughness

The impact toughness measured at room temperature is shown in Fig. 15. The impact toughness of electro-slag cast steel is slightly lower than that of forged steel. The impact toughness of quenched and tempered specimens is lower than the annealed specimens. There is a slight directional difference for impact toughness of the ESC specimens for the annealed condition. The specimens from horizontal direction show slightly higher impact toughness than those machined from the vertical direction. As the directional differences are caused by the differences in the radial-axial orientation of crystal structure, it disappears at the quenched and tempered condition.

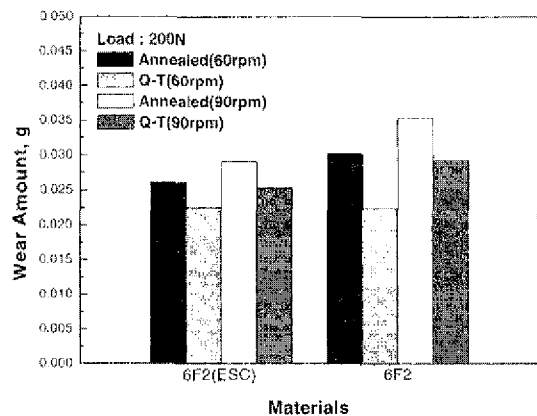

Fig. 16 Wear amount at different velocities

3.4 Wear resistance

Figure 16 shows the wear resistance expressed by wear amount at different rotational velocities. The amount of wear for the quenched and tempered specimens is less than that of the annealed specimens. The electro-slag cast specimens show better wear resistance than the forged ones. With increasing rotation speed, the amount of wear increases, but the sensitivity to velocity is lower in case of electro-slag cast material.

3.5 Thermal fatigue

Figure 17 shows the variation of tensile and compressive stress with thermal cycles under the thermal fatigue test condition described in section 2.2.4.

The tensile stress generated at T_{\min} is always higher than the compressive stress generated at T_{\max} on an absolute scale, because of the difference in flow stress with temperature. The 6F2 (ESC) steel requires a higher number of cycles to failure as compared to the forged 6F2 steel for both the annealed and the quenched and tempered conditions.

3.6 Thermal Shock Resistance

Figure 18 shows the temperature and the load variation with time for annealed 6F2 (ESC) steel, for a start temperature of 800°C.

The specimen fractured during the cooling due to the thermal contraction and the simultaneously applied tensile force. The thermal shock resistance of 6F2 (ESC) steel is estimated to be

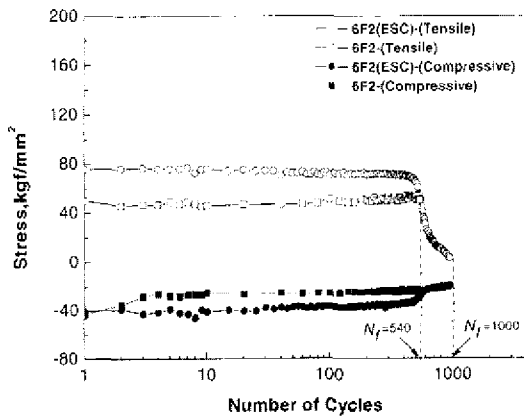

(a)

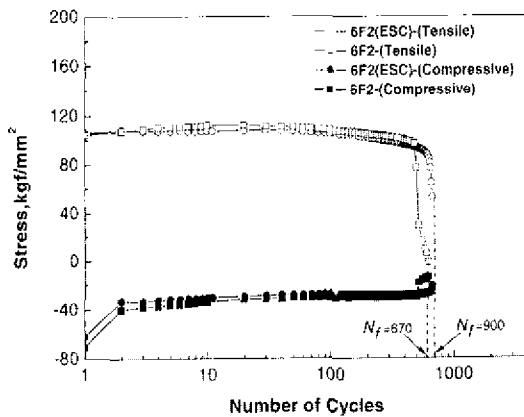

(b)

Fig. 17 Variation of the tensile and compressive stress with cycle number for (a) annealed and (b) quenched and tempered specimens

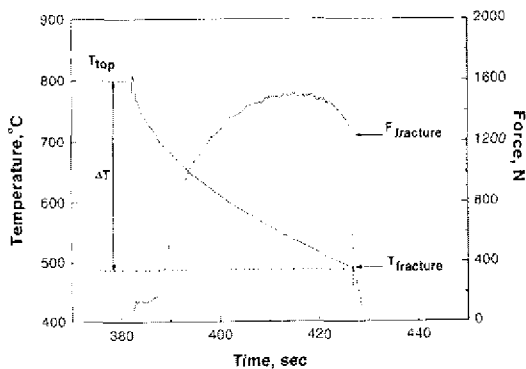

Fig. 18 Temperature and load variation with time

approximately 300°C. The thermal and mechanical properties in the temperature range of 500-800°C are the contributing factors to the resultant

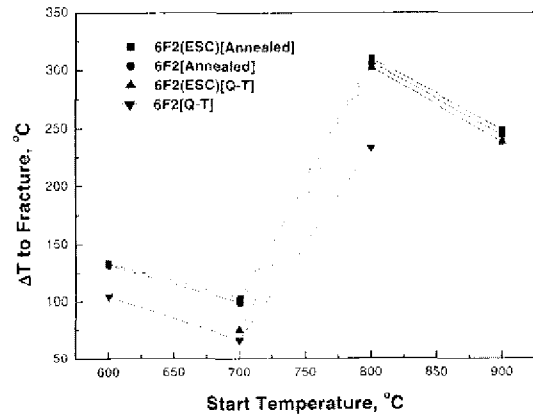

Fig. 19 Thermal shock resistance at various start temperatures

thermal shock resistance.

Figure 19 shows measured thermal shock resistance values at various start temperatures. Thermal shock resistances of the annealed steels are higher than those of the quenched and tempered steels. In the annealed condition, both forged 6F2 and 6F2 (ESC) show similar thermal shock resistances. For the quenched and tempered condition, the electro-slag cast steel shows better thermal shock resistance than that of the forged steel. The increase in thermal shock resistance at the temperature range 700-800°C is mainly due to the increased hot ductility at elevated temperature. At the temperature above 800°C, the enhanced local plastic deformation caused by decreased deformation resistance accelerate early failure during the subsequent loadings. For the good thermal shock resistance, both elastic and plastic deformation before fracture at elevated temperature must be accommodated. The superior thermal shock performance is a direct result of the optimal combination of various mechanical properties. The thermal shock results shown in Fig. 19 are consistent with the tensile properties at elevated temperature, shown in Figs. 12 to 14.

4. Conclusions

In this study, the mechanical and thermal properties of electro-slag cast tool steel were evaluated by various thermal and mechanical tests and compared with the properties of forged hot

working tool steel. AISI-6F2 was selected as the material, for the study and the chemical composition of electro-cast steel is almost the same as that of forged AISI-6F2.

The results obtained in this study can be summarized as follows

(1) In the quenched and tempered condition, both the forged and electro-slag cast steels show similar tensile strengths and hardnesses, while in the annealed condition, the electro-slag steel shows significantly higher tensile strength and hardness than forged steel

(2) The quenched and tempered steels for both the forged and electro-slag cast materials exhibit similar elongations. For the annealed condition, the forged steel has a higher elongation than the electro-slag cast steel

(3) The impact toughness of quenched and tempered steels is lower than that of annealed steels. There is a slight directional difference for the impact toughness for electro-slag cast specimens. The specimens machined in the horizontal direction exhibit slightly higher values than those machined in the vertical direction

(4) The wear of the quenched and tempered steels is less than that of annealed steels. The electro-slag cast steel shows better wear resistance than forged steel. With increasing rotation speed, the amount of wear increases, but the sensitivity to velocity is less for the electro-slag cast steel

(5) The thermal fatigue resistance of electro-slag cast steel is superior to the forged steel, due to the higher hot tensile strength

(6) The thermal shock resistances of the annealed steels are higher than those of quenched and tempered steels. In the annealed condition, both the forged and electro-slag cast steels have similar thermal shock resistance. In the quenched and tempered condition, the electro-slag cast steel has better thermal shock resistance than the forged steel

(7) In examining the various thermal and mechanical properties that were measured in the study, it can be stated that an electro-slag cast tool steel is comparable to a forged tool steel

References

- Baligidad, R G, Prakash, U and Krishna, A R, 1998, "Effect of Carbon Addition on Structure and Mechanical Properties of Electroslag Remelted Fe-20wt % Al Alloy," *Material Science and Engineering A*, Vol 249, pp 97~102
- Collin, M and Rowcliffe, D, 2000, "Analysis and Prediction of Thermal Shock in Brittle Materials," *Acta Materialia*, Vol 48, pp 1655~1665
- Dieter, G E, 1987, *Mechanical Metallurgy*, 3rd edition, McGraw-Hill, New York, NY, USA
- Kim, D. H., Ryu, J H, Shin, J H and Lee, S, 1996, "Effect of Microstructure on Thermal Fatigue Properties of Roll Materials. I Evaluation of Thermal Fatigue Properties," *Journal of the Korean Institute of Metals and Materials*, 34, pp 29~36 in Korea
- Kwon, J D, Ihn, J H, Park, J C and Choi, S J, 2002, "An Evaluation of Cast Stainless Steel (CF8M) Fracture Toughness Caused by Thermal Aging at 430°C," *KSME International Journal*, Vol 16, No 7, pp.902~910 in Korea
- Medovar, B I, 1989, *Special Electrometallurgy A Review*, Harwood Academic Publishers, Chur, Switzerland
- Medovar, B I and Boiko, G A, 1991, *Electroslag Technology*, Springer-Verlag, New York, NY, USA
- Moon, Y H, Kim, J W and Van Tyne, C J, 2003, "Thermal Shock Resistance of Electro-Slag Cast Steel for Hot Working Tools," *Proceeding of the International Conference on Advances in Materials and Processing Technologies*, Dublin, Ireland, July 8-11, pp 1128~1131
- Norstrom, L A, 1982, "Performance of Hot-Work Tool Steels," *Scandinavian Journal of Metallurgy*, Vol 11, pp 33~38
- Paton, B E, Medovar, B I and Boiko, G A., 1980, *Electroslag Casting*, Naukova Dumka Publishers, Kiev, USSR
- Starling, C M D and Branco, J R T, 1997, "Thermal Fatigue of Hot Work Tool Steel with Hard Coatings," *Thin Solid Films*, Vol 308-309, pp 436~442